

The Fitzgerald™

OF6320 Series



SPECIFICATION SHEET



celebrating 25 years

Product Specifications subject to change

The Fitzgerald™ Fan Assembly – OF6320**

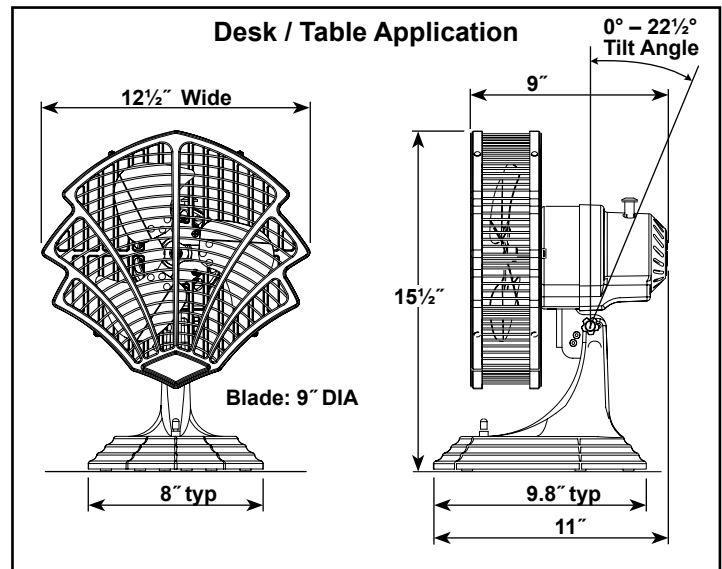
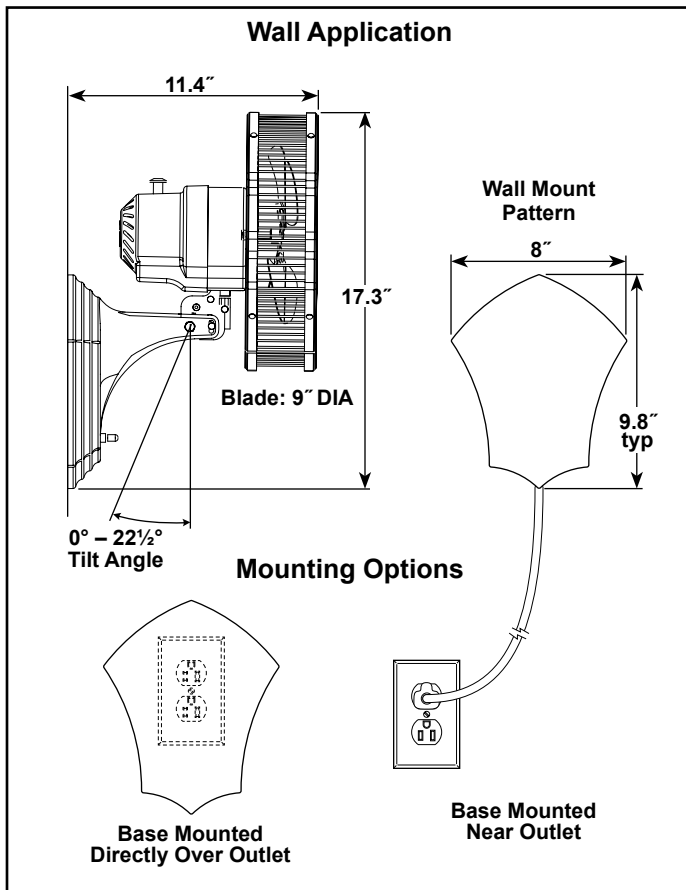

Available Finishes	
OB	Oil-Rubbed Bronze
SN	Satin Nickel

All Dimensions Shown In Inches

ELECTRICAL REQUIREMENTS:

Requires a grounded electrical supply line of 120 volts AC, 60 Hz, 15 amp circuit. 8 ft power cord included.

MOTOR SPECS:

75 x 18 motor is designed for optimal performance with this fan. 220 VAC, 50 Hz export version available.

CONTROL / SPEED:

Features a 4-position rotary switch control (high, medium, low and off).

High—1,700 rpm; Med—1,450 rpm; Low—1,300 rpm

FEATURES:

- Includes 8 ft power cord
- Oscillates 82°
- Can be mounted on wall, near or directly over outlet (mounting bracket included)
- Includes protective rubber feet
- Weighs 10 lbs
- Ships fully assembled

LOCATION USE:

Fan is rated for dry locations only.



10983 Bennett Parkway
Zionsville, IN 46077
Toll Free (888) 567-2055
FAX (866) 482-5215

Outside U.S. call (317) 733-4113

Visit Our Website www.fanimation.com

